

IMPORTANT: PLEASE READ THIS MANUAL CAREFULLY

POOL SCOUT MANUAL



POOL SCOUT is designed and made by an ISO 9001 certified manufacturer. Our mission is to provide the highest combination of quality, service and price to support our distributors and customers.

DIRECTORY

1. GENERAL	3
2. PRODUCT & SPARE PARTS	3
3. GENERAL FIGURE	4
4. BATTERY INSTALLATION / REPLACEMENT	4
5. OPERATION & CONTROL	5
6. POSITION FOR INSTALLATION	8
7. INSTALLATION & REMOVAL OF MAIN UNIT	9
8. ADJUSTMENT OF SUBMERSIBLE SENSOR TUBE	10
9. TEST	11
10. REMOTE RECEIVER	12
11. TO SWIM IN THE POOL	13
12. SWIMMING POOL SAFETY TIPS	13
13. WARRANTY AND REPAIRS	14
14. ATTENTION	14
15. KEEP IN MIND	15
16. TROUBLESHOOTING	15

1. GENERAL

POOL SCOUT is the result of a quality, ingenious design and state-of-the-art manufacturing techniques. It is an electronic monitoring system that automatically sounds an alarm when children or pets fall into your unsupervised pool. POOL SCOUT is a portable, self-contained, lightweight unit that is safe and simple to operate. Entry into the pool will be detected by the unit's electronic sensor, triggering a loud pulsating alarm to quickly alert bystanders.

2. PRODUCT & SPARE PARTS

The device is packaged in a shipping box that minimizes the chance of damage due to handling. Check for damage and confirm that the contents of the box include the following items (see Fig.1).

- 1-Main unit
- 2-Remote receiver
- 3-Adapter (DC 12V 200mA)
- 4-Stainless steel screws (long 2pcs, short 2pcs)
- 5-Plastic swells screws (long 2pcs, short 2pcs)
- 6-Small tube (3cm 3pcs, 2.4cm 1pc, 3.9cm 1pc)
- 7-Manual
- 8-Dry cell batteries required, (not includes, 6pcs x LR20 1.5V size D)

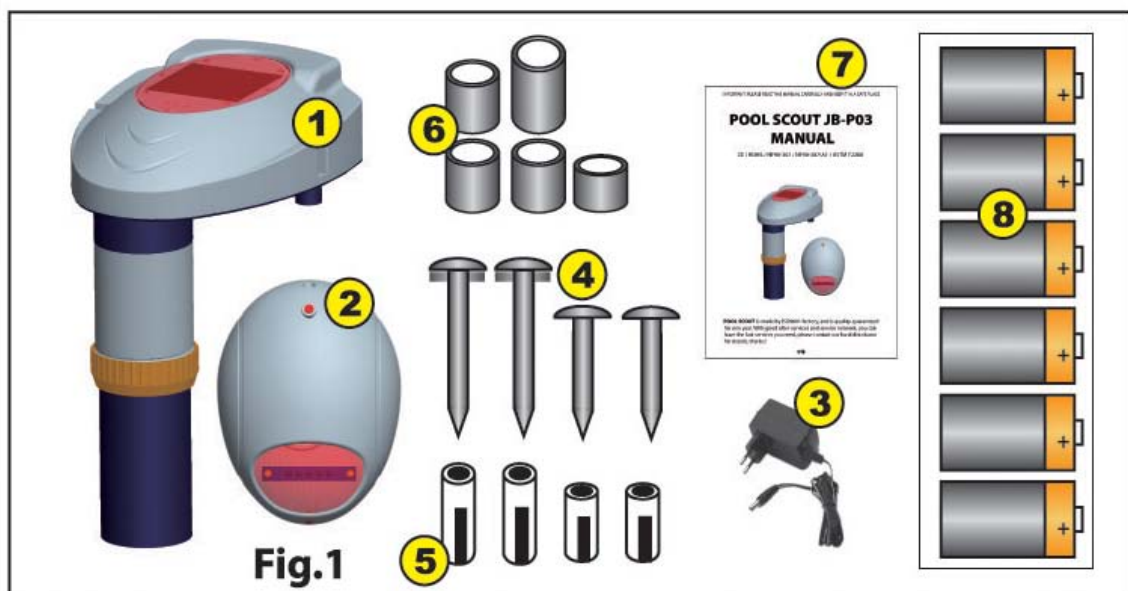

If any of the above items are missing, contact either the place of purchase or our distributor for replacement.

3. GENERAL FIGURE (see Fig 2-1)

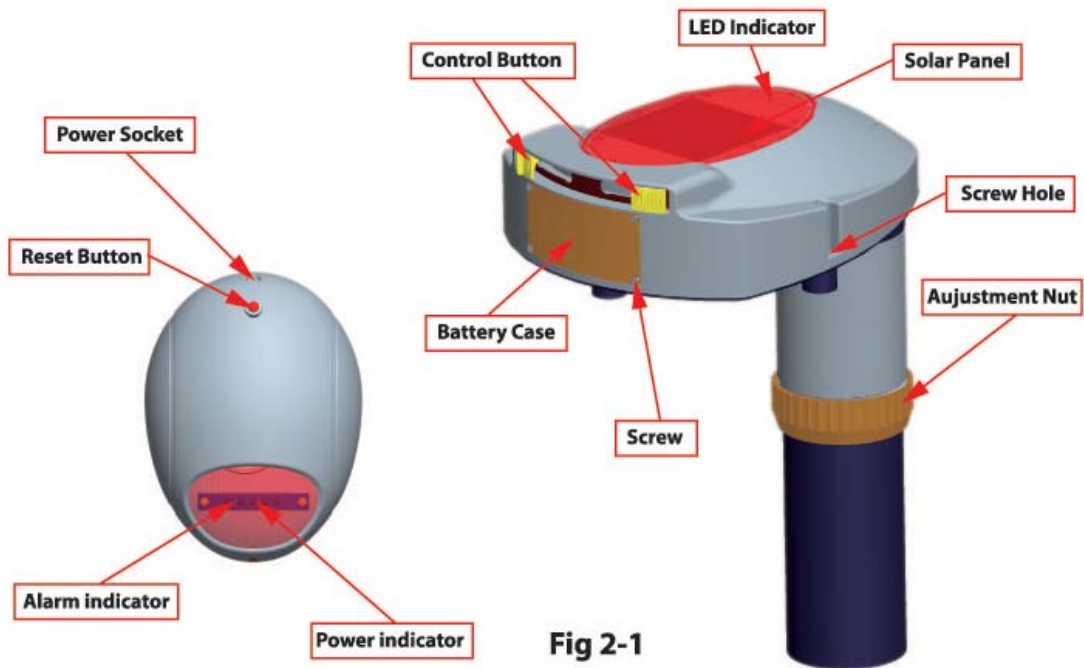

4. BATTERY INSTALLATION / REPLACEMENT

4.1 The device is powered by 6 LR20 1.5V alkaline batteries, install and replace batteries as follows: (battery are not include)
Remove the screws in rear battery-case (see Fig. 3-1/2/3/4).

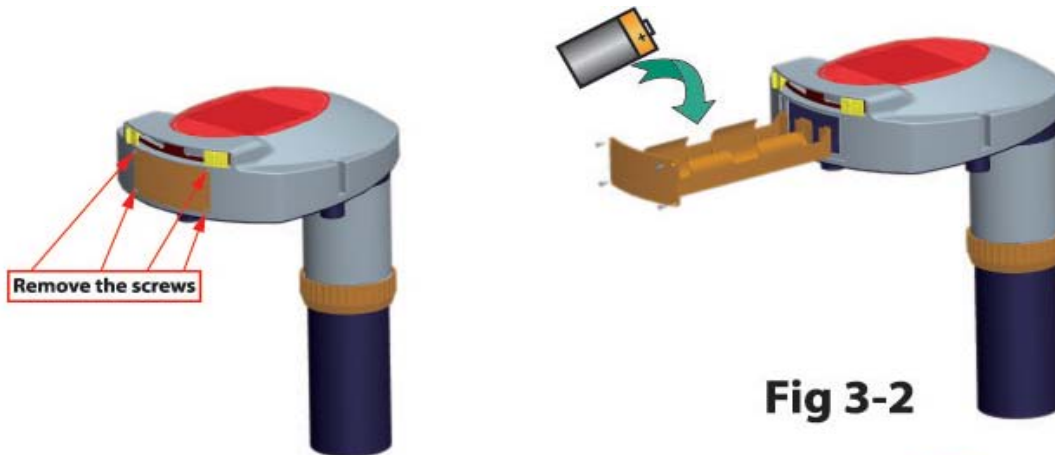

Fig 3-1

Fig 3-2

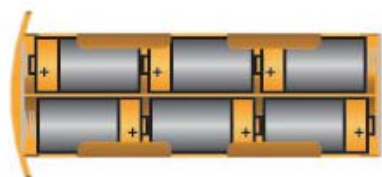

Fig 3-3

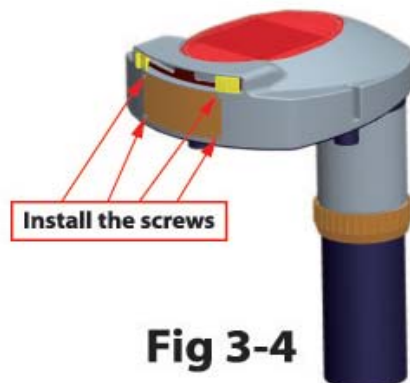

Fig 3-4

4.2 With the low battery warning function, the main unit beeps every 20 seconds to indicate to replace the batteries with new ones.

Keep in mind: It is important not to let the rubber washer come off.

5. OPERATION & CONTROL

5.1 Your pool alarm includes an intelligent system which analyzes the surface of the pool and can automatically reset. It is easy to operate, and offers many different functions, which are accessed through the control buttons.

Attention:

1. To move the control button, first press down on it to prevent accidental operation by a child.

2. For clarity, the left button will be referred to as "B1" and right button as "B2" (see Fig. 4).

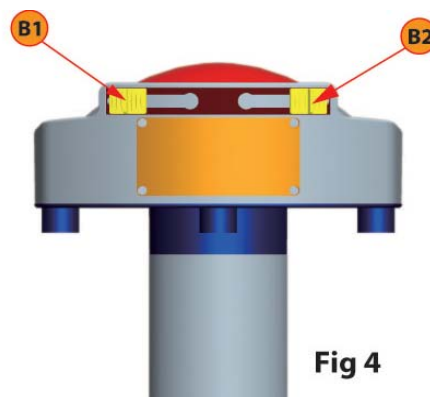

Fig 4

3. Status indication

- A. Surveillance status - Green light flash at intervals
- B. Sleep/Swimming status - Yellow light flash at intervals
- C. System-Off status - Red light flash at intervals
- D. Alarm status - Red light keep flashing

5.2 System Start

Move "B2" to the right, the green light will start to flash, indicating the system is in surveillance status (see Fig. 5).

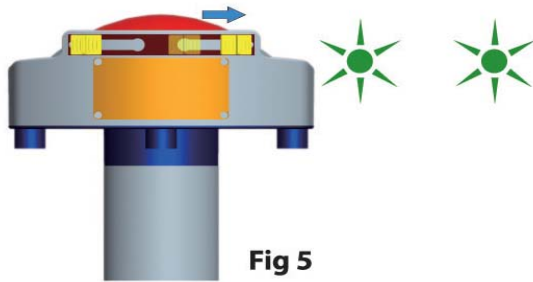

5.3 System Turn off

Move "B2" to left, system turns off (see Fig. 6).

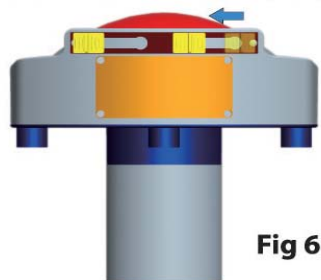

Warning: Please turn off the system only when away on holiday or if the pool is not in use for a long time.

5.4 Reset

If the system sounds the alarm, it will continue for 6 minutes, if you want to stop it, simply move "B1" to any position and the system will return to surveillance status (see Fig. 7-1/2).

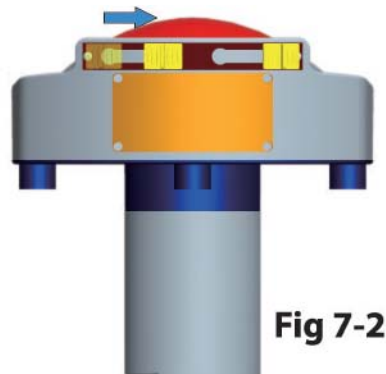
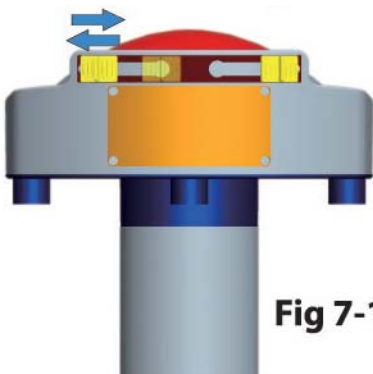

5.5 Sleep/Swimming status

Move "B1" to the right and you will hear "WO WO..." and a yellow light start to flash, indicating the system is in Sleep/Swimming status (see Fig. 8).

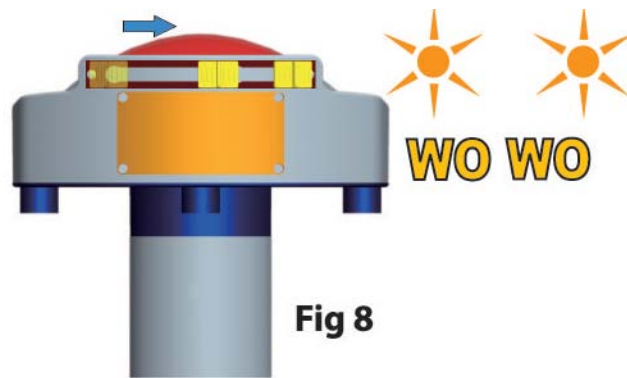

Attention:

1. Sleep/Swimming status is available only when the alarm has not been triggered; if so, please reset the system (refer to 5.4).

2. When the pool water calms down, system will activate automatically in 100 seconds and enter Surveillance status.

5.6. Manual activate

If you want to stop the Sleep/Swimming status immediately, just move "B1" to the left and you will hear "WO WO" twice and a green light will start to flash, it indicates the system has been re-started (see Fig. 9).

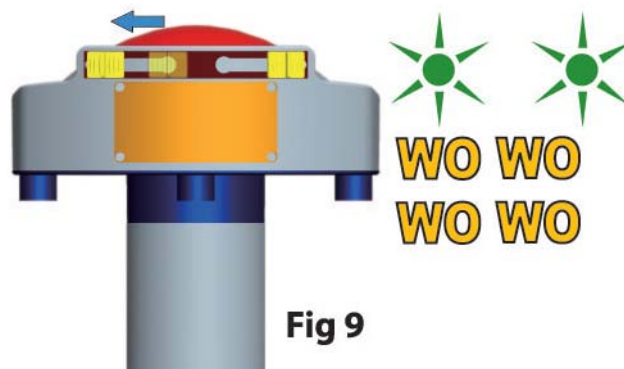

5.7 System-off status

When the system is turned off, a red light will flash at intervals (Fig.10)

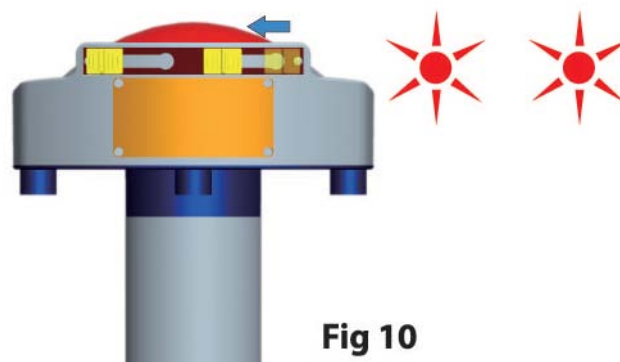

5.8 Low batteries

If the main unit beeps every 10 seconds, it indicates the batteries are running low; please replace them immediately (Fig.11).

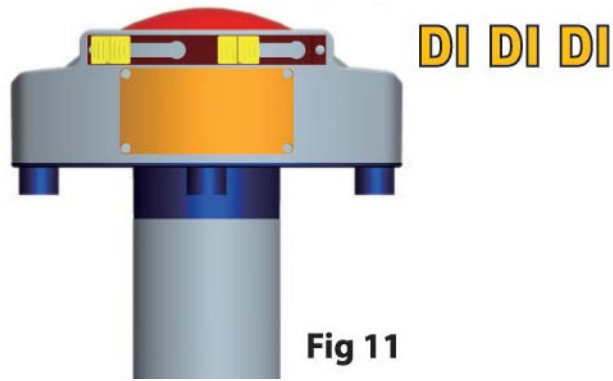

6. POSITION FOR INSTALLATION

The figures below indicate the proper place to install the main unit, if you have a pool bigger than 16x32 sq. feet, or a pool with two return lines, or an irregularly shaped pool, please contact our distributor to clarify the number of alarms needed and the proper location for installation (see Fig. 12-1/2/3/4);

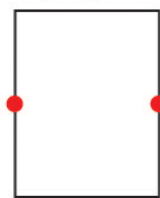

Fig 12-1

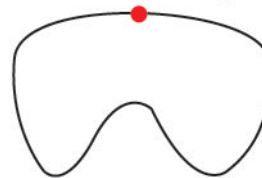

Fig 12-2

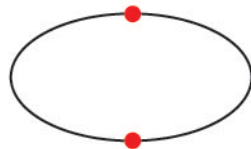

Fig 12-3

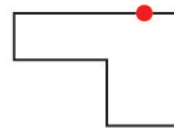

Fig 12-4

7. INSTALLATION & REMOVAL OF MAIN UNIT

7.1 Our alarm can be adjusted to apply different water levels with a submersible sensor tube, we suggest a gap of 1-2cm between the tube and the pole wall (see Fig. 13-1/2).

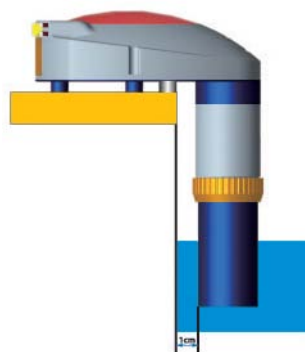

Fig 13-1

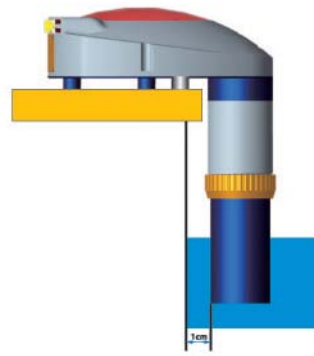

Fig 13-2

7.2 Tools needed: percussive drill, dia.8mm; cross screwdriver, dia.6mm.

7.3 Procedures:

A. First turn the system to Off status

B. choose the proper place to install, mark the position for hole drilling, and drill two holes 3-4cm deep; (see Fig. 14-1/2)

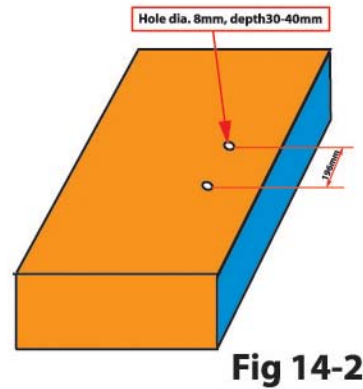
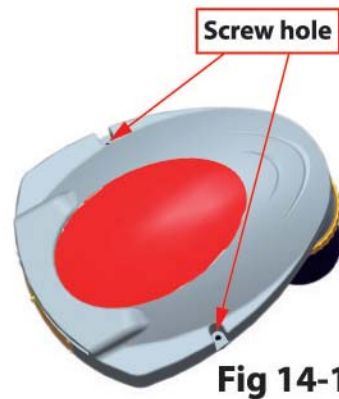

7.4 Installation for kinds of pool bases (see Fig. 15-1/2/3/4).

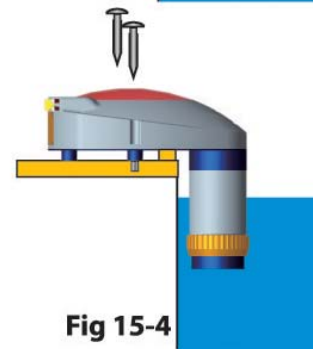
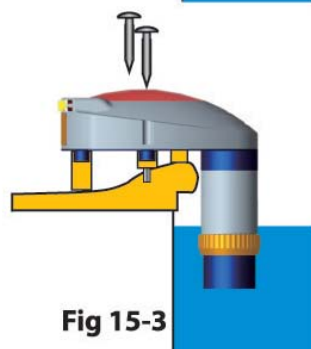
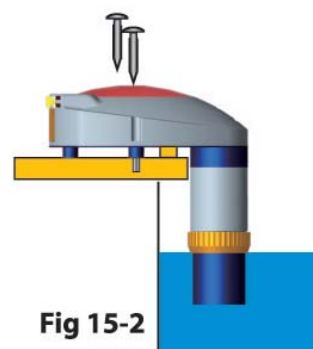
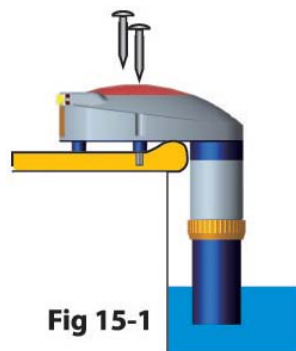

7.5 To remove the main unit, use a screwdriver to take off screws.

8. ADJUSTMENT OF SUBMERSIBLE SENSOR TUBE

8.1. It is suggested that the sensor tube should be submerged 10 cm into water (see Fig. 16) Do not touch the sensor directly with your hand.

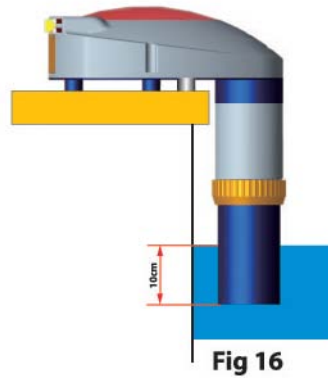

8.2. Turn the nut counterclockwise to loosen it, move the extension tube up and down to the correct position, then turn the nut clockwise to tighten it (see Fig. 17-1/2/3/4).

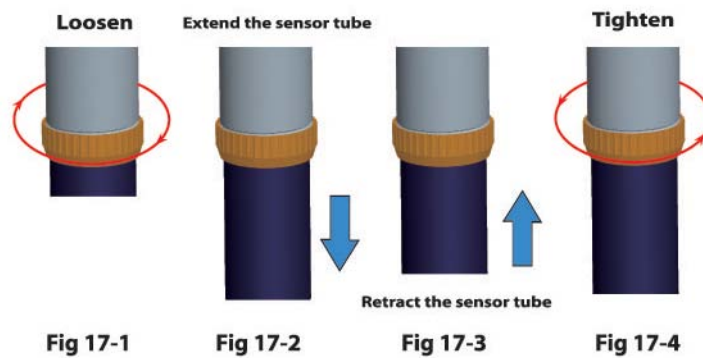

9. TEST

9.1 To make sure the device is working effectively, we suggest that you test the alarm before each use:

First set the alarm system to Surveillance status, then drop a child simulator (e.g. four 1.5L bottles full of water, not less than 6kg) into the pool at the farthest point from main unit, the alarm system will sound the alarm within seconds when waves reach the sensor (see Fig. 18-1/2/3).

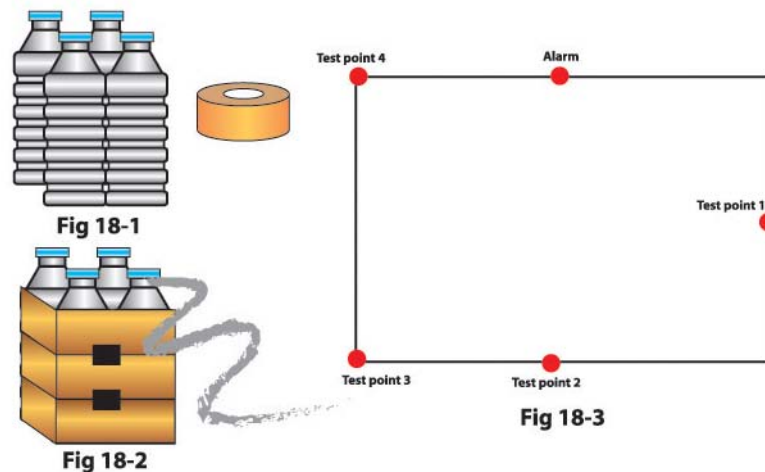

Wait until the water calms down, and then repeat the test in other places to

make sure the alarm system works well.

9.2 Choosing a test location (see Fig. 18-3).

Attention: make sure the submersible sensor tube is 10cm deep in water, otherwise, the system may not achieve the best performance.

10. REMOTE RECEIVER

10.1. Place receiver within 65 feet of the main unit.

10.2. You will have a red LED for power indicator.

10.3. In case of power failure, battery back-up will be used inside; for battery installation or removal, see Fig. 19. (the battery is mandatory)

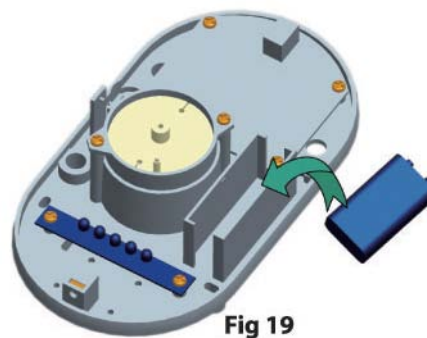

Fig 19

10.4. The red button on cover is a reset button, you can reset receiver when the alarm sounds.

10.5. When the receiver alarm sounds, a red light will also flash, both to attract attention and help alert those who may be hard of hearing.

10.6. Do not place in the basements or close to metal walls. Be sure that the red light on the remote is on, remember, the receiver will only go off when the main unit does.

10.7. When using the receiver for the first time, it will need a few seconds to synchronize with the main unit.

10.8. If your remote receiver is not getting a clear signal or is getting no signal from the main unit, try the following, before plugging the adapter in the power supply, be sure to stretch out the cord; do not leave it tied in a bow as packaged. When the main unit alarm sounds, if the receiver alarm does not sound, move the remote receiver to different locations and stand back for a few seconds for the remote receiver to pick up the signal. You may only have to move your receiver a little to the left or right to bring in the signal. In some cases you might have to move the receiver to a different location or another

room. If you still cannot get a signal on your receiver, please ask to change. Take off the adapter and test the receiver as mentioned above to see how it works without electricity power. If it can still receive the signal, you can now use the receiver safely.

Attention: remember to install the back-up battery before use.

11. TO SWIM IN THE POOL

11.1. Move "B1" to the right side, the system will beep several times and a yellow light will flash, indicating the system is in Sleep/Swimming status.

11.2. After setting the system to Sleep/Swimming status, you will have 100 seconds to start swimming, or the alarm system will activate automatically.

The alarm will not sound when you are swimming.

11.3. After swimming, wait until the water calms down, move "B1" to the left side to activate the alarm system, or wait a few seconds for the system to activate automatically.

Attention: make sure the system is activated before leaving the pool.

12. SWIMMING POOL SAFETY TIPS

- Supervise children at all times.
- Never permit swimming alone. Never leave a child alone, even to answer the telephone.
- Always remove the entire solar cover from a pool before swimming.
- Remember that alcohol and pools do not mix.
- Have your pool area fenced and the gate locked to prevent unauthorized entry to the pool, and install a gate alarm.

- Lock and secure all doors in the house which permit easy access to the pool, and install a door alarm.
- Have a responsible adult teach swimming and water safety to your children.
- Maintain clean, clear water in the pool.
- Do not swim during storms.
- Do not permit bottles, glass, or sharp objects to be used around the pool.
- Ask your pool dealer how you can improve your pool safety-they will be glad to assist you.
- Above all: remember that common sense, awareness, and caution will allow you to enjoy your pool.

13. WARRANTY AND REPAIRS

POOL SCOUT is sold with a one year limited warranty to cover defects in parts

and workmanship from date of purchase (retain proof of purchase).

If our alarm exhibits a defect, please contact our distributor. Unauthorized returns will not be accepted, repair is only provided when the unit is returned to the manufacturer.

All pool alarms will false alarm on occasion for different reasons. False alarms can be minimized; however, it is important to remember that a false alarm is better than no alarm at all. WEATHER & WIND-Our Unit sits stationary on the deck of the pool so the wind will not affect the alarm unit itself. Wind may trigger a false alarm if it is strong enough or steady enough and causes the water in the pool to rock or splash up and down the pool wall. When the water in the pool moves up and down the alarm sensing tube, it may trigger the alarm. On extremely windy days when the pool water is rocking it is advised to set the alarm in Sleep/Swimming status.

Light wind or rain will not affect the alarm.

14. ATTENTION

POOL SCOUT has been designed to aid in the detection of unwanted intrusions into unsupervised pools. POOL SCOUT IS A SAFETY ALARM SYSTEM AND NOT A LIFE SAVING DEVICE. "This device is not intended to replace other considerations -e.g. adult supervision, lifeguards, fences, gates, pool covers, locks, etc., and some devices may not detect gradual entry."

POOL SCOUT is made of sturdy Plastic+UV. Because the alarm is electronic and mechanical, great care should be taken not to drop the unit, as it may break. Sun and rain will not hurt the alarm.

15. KEEP IN MIND

- DO read the manual carefully
- DO install the alarm properly
- DO test the alarm properly
- DO adjust submersible tube properly to meet the water level
- DO not leave until the unit is activated after swimming
- DO replace the batteries when low
- DO supervise the pool, when the alarm is in Sleep/Swimming status
- DON'T start your alarm immediately after swimming.

-If your pool has a gradual slope less than 30% with no drop-offs, this pool alarm is not enough to monitor it; you need to use another alarm system for complete protection.

-Turn off the system only when pool is not to be used for a long time or the family is away on holiday, and remember to start the alarm system before using the pool or when you return from holiday.

- If you purchase the Pool Scout with a solar panel, we still advise that you install the dry cell batteries (6 x LR20 1.5v size D) in case of periods without sunshine!

16. TROUBLESHOOTING

Q: Does your alarm system not work when tested?

A: check if the batteries are installed correctly and "B2" is on the right side.

Q: Can you not move the button?

A: be sure to press down before moving it

Q: Do you have false alarms caused by strong wind?

A: move "B1" to the right to Sleep/Swimming status.

Q: Why does the alarm stop after swimming when I activate the system?

A: the water has not calmed down; be sure to activate system after the water calms down.

Q: If my pool is bigger than 16x32 square feet, do I need an extra alarm system?

A: yes

Q: Why is there no alarm when I drop an object in the pool?

A: check that the submersible sensor tube is 10 cm in the water, or check the weight of the object.

Q: Why doesn't my alarm work with solar power?

A: the battery is not charged, please charge it before use.

Q: I want to battery-power the alarm instead of solar power, is this ok?

A: Yes, but you will need to install dry cell batteries for days without sunshine.

Q: I use the alarm system indoor with no sunshine; how can I power it?

A: use dry cell batteries (6 x LR20 1.5V size D)

Q: I do not want to drill a hole in my pool; what should I do?

A: place the alarm on the edge of the pool.

Q: Is it ok to immerse the alarm in water for a long time?

A: No

Q: The alarm fell in the water and was there a long time before I realized it. What should I do?

A: turn off the system and let it dry at first, and test it before using.

Q: Can it be used in lakes, spas, fish ponds, etc.?

A: Yes. For use in a fish pond, another accessory is needed, please contact our local distributor for details.

Q: Can one receiver work with multiple main units, or can one transmitter work with multiple receivers?

A: Yes.

Q: My receiver cannot get a signal; what should I do?

A: check if the receiver is installed on metal objects or if something is weakening the signal.

NOTE:

THE MANUFACTURER IS NOT RESPONSIBLE FOR ANY RADIO OR TV INTERFERENCE CAUSED BY UNAUTHORIZED MODIFICATIONS TO THIS EQUIPMENT. SUCH MODIFICATIONS COULD VOID THE USER AUTHORITY

REMINDING

This device complies with Part 15 of the FCC Rules. Operation is subject to the following two conditions:

- (1) this device may not cause harmful interference, and
- (2) this device must accept any interference received, including interference that may cause undesired operation

Changes or modifications not expressly approved by the party responsible for compliance could void the user's authority to operate the equipment.

This equipment has been tested and found to comply with the limits for a Class B digital device, pursuant to part 15 of the FCC Rules. These limits are designed to provide reasonable protection against harmful interference in a residential installation. This equipment generates uses and can radiate radio frequency energy and, if not installed and used in accordance with the instructions, may cause harmful interference to radio communications. However, there is no guarantee that interference will not occur in a particular installation. If this equipment does cause harmful interference to radio or television reception, which can be determined by turning the equipment off and on, the user is encouraged to try to correct the interference by one or more of the following measures:

- Reorient or relocate the receiving antenna.
- Increase the separation between the equipment and receiver.
- Connect the equipment into an outlet on a circuit different from that to which the receiver is connected.
- Consult the dealer or an experienced radio/TV technician for help.